

Single-Mode Digital U-Type Module with Optical Isolator



Innovative Photonic Solutions' proprietary Wavelength Stabilized Laser Diode features high output power with narrow spectral bandwidth. The laser's stabilized peak wavelength remains "locked" regardless of case temperature (15 to 45 °C). Devices can be spectrally tailored to suit application needs and offer side mode suppression ratios (SMSRs) better than 40 dB, thereby providing extremely high signal-to-noise ratio and making these sources ideal for Raman spectroscopy and pump laser applications. The laser is integrated with high performance laser drive and temperature control electronics in a compact package. In addition to integration into systems, IPS' OEM U-Type module is designed to "drop in" to our UL/CE and IEC certified turn-key modules to offer wavelength flexibility at a lower cost.

Standard Wavelengths

All specified wavelengths are measured "in-vacuum"

Applications

This laser package is designed for OEM Integration and is ideal for:

- High Resolution Raman Spectroscopy
 - Confocal Microscopy
 - Raman Imaging
 - Portable Raman
 - Process Raman
- Direct-Diode Frequency Doubling
- Fiber Laser Seeding
- Metrology & Interferometry
- Remote Sensing

Key Features

- High-Power Single-Spatial-Mode, Single-Frequency Output
- Narrow Spectral Linewidth (< 100 MHz FWHM)
- High Power Single-Mode Fiber Coupled Output
- Excellent Beam Quality ($M^2 < 1.1$)
- Integral ESD Protection & Thermistor
- Temperature Stabilized Spectrum (< 0.007 nm/°C)
- Low Power consumption (< 5.5 W)
- > 45 dB SMSR Typical
- 3" x 2.5" x 0.69" Package Weighing < 4 oz
- Integral single stage optical isolator
- Dual stage optical isolator available >1000nm
- Available with a "U-Type switch box" to enable plug-and-play
- External fiber patch cord sold separately

780nm	852nm
783nm	1030nm
785nm	1053nm
808nm	1064nm

Specifications



Wavelength Tolerance	+/- 0.5nm
Spectral Linewidth	<100MHZ
Wavelength Stability Range	15 - 45 °C
SMSR	45 - 55 dB typical
Polarization Extinction (PER)	>17 dB (20 dB Typical)
Polarization Orientation	Standard is PM Slow Axis
Output Power Stability	1% typical
Modulation Rate	CW to 1KHz (for 10% power to CW) up to 10 KHz for 50% power.
Warm-Up Time	10 seconds from cold start
	1.5 seconds from warm start

λ (nm)	Output Power (mW)	Base Part Number
780	25	I0780SU0025PA-IS-USB
783	25	I0783SU0025PA-IS-USB
785	25	I0785SU0025PA-IS-USB
808	25	I0808SU0025PA-IS-USB
852	20	I0852SU0020PA-IS-USB
1030	50	I1030SU0050PA-IS-USB
1053	50	I1053SU0050PA-IS-USB
1064.X	50	I1064.XSU0050PA-IS-USB

Part Schema

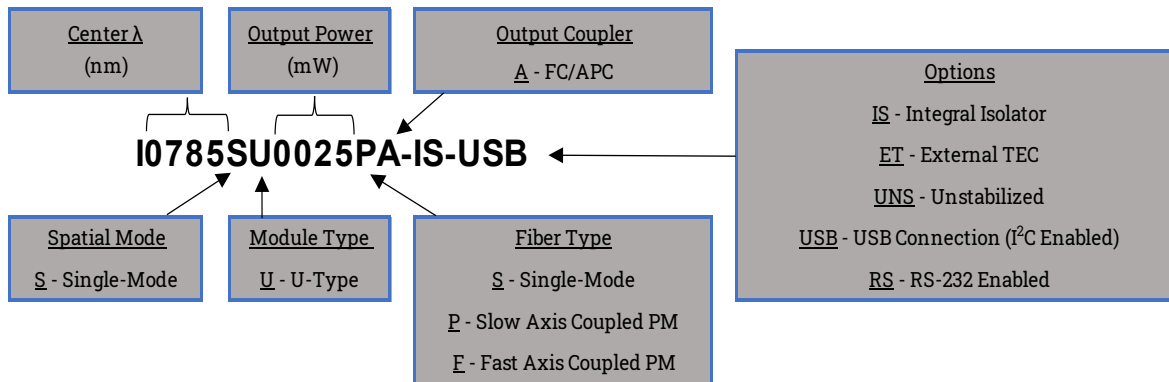

Selected Data



Supply Voltage	4.9V min to 5.1V max
Power Consumption	3.5W typical, 5.5W maximum
Photodiode Current	30 μ A
Laser Set Point Control (LD SET)	900mA to 1000mA when pin 2 grounded

Optical Fiber Options	Single-Mode Fiber
	Polarization Maintaining, Panda Type
Connector	FC/APC
Electrical Connector	10-pin, Molex #53014-1010 (mating connector: 51004-1000)
Module Dimensions	3.0 x 2.5 x 0.69 inches
Module Weight	100 grams (3.5 ounces)
Case Material	Anodized Aluminum
Operating Temperature	10 to 45 $^{\circ}$ C
Cooling air flow (internal)	100 LRM with attached heat sink
Environment	0-80% Humidity, non-condensing
Storage Temperature	-10 to 55 $^{\circ}$ C

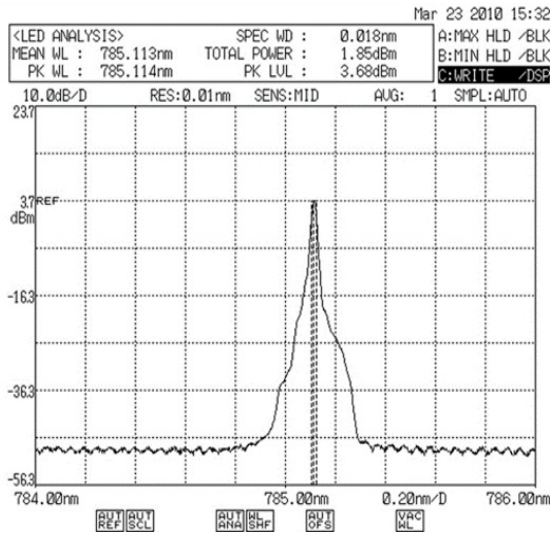

Electrical Specs

Pin	Pin Label	Function
1*	V+	Power Supply: 5V-12V. For lasers operating <600mW, a 5V minimum is required. For lasers operating >600mW, a minimum of 9V is required, 12V recommended
2^	VBIAS ENABLE (Set Enable)	For analog control: Enable external laser power control through pin 8 (LD VBIAS): High (>3.6V up to V+ supply voltage) = Enable Low (GND) = Disable The same functionality is emulated via software as a replacement for this analog control.
3	SCL/TX	I ² C: SCL standard (RS-232: TX; board by request)
4	SDA/RX	I ² C: SDA standard (RS-232: RX; board by request)
5**	GND	Ground
6*	V+	See Pin 1
7	Enable	Laser Enable: TTL High (>3.6V up to V+ supply voltage) = Enable TTL Low (GND) = Disable Pin may also be used for PW modulation at a rate of 1kHz.
8^	LD VBIAS (LD Set)	Laser power setpoint - Enables analog external control of laser drive current. Drive VBIAS Enable (pin 2) high to enable this option. Drive voltage between 0V and 1V. The voltage bias will be a 1:1 ratio to the laser drive current. See Operational Note #3.
9^	PD+	For analog readout. Connect voltmeter to PD+ (pin 9) and GND for photo diode V output (0V-3.3V). The same functionality is emulated via software as a replacement for this analog control.
10**	GND	Ground

Custom Capability

- Custom wavelengths available upon request
- FC/PC or FC/APC output coupler
- Single-mode or Polarization-maintaining fiber available with orientation in either fast or slow axis
- External TEC (e.g. No TEC inside of package optional)

Pins 1, 2, 6, 7 and 10 are required for laser operation

Notes: *Power must be supplied to both V+ pins (pin 1 and pin 6), **GND must be supplied to both GND pins (pin 5 and pin 10). ^ Pins 2, 8, and 9 are optional for analog control/readout

Mechanical Drawings

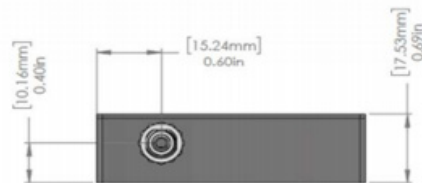
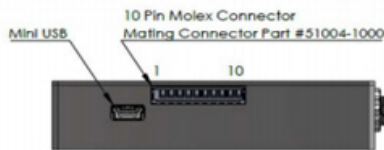
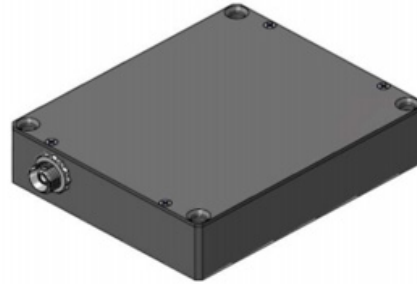
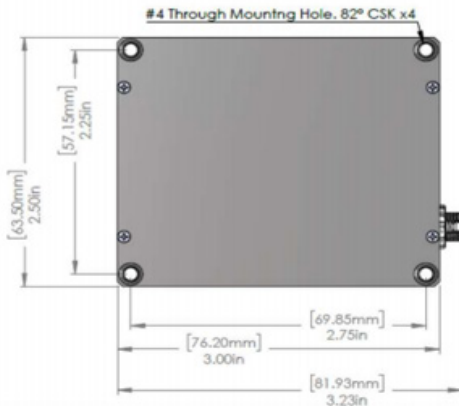

- Connector Options:
1. FC/PC (M8 Thread)
 2. SMA 905 (1/4"-36 Thread)

Operational Notes

1. Switch box, heat sink, and power supply are not included with module. These items are available as accessories.
2. Do not retro-reflect beam! This can cause Catastrophic Optical Damage (COD) and is not covered under warranty unless optical isolator is included.
3. A VBG-locked Single-mode laser will experience mode hops as the temperature and driver current are changed (see [Mode-Hop White Paper](#)). For this reason, IPS profiles and sets both the current and temperature for this module and does not allow user adjustment.
4. To adjust power output, IPS recommends Pulse Width Modulation (PWM) to adjust AVERAGE power rather than using pin 8 (LD SET) for single-mode diode lasers. See Note 2.
5. By using PWM, user can adjust average power from 10% to 100% in digital increments by setting pulse width and duty cycle. For example, if a 50% duty cycle is selected, the laser will be on 50% of the time, and off 50% of the time, making the average power equal to 50% of the CW output power. The sample will experience a lower average power. Rise/fall time is approximately 20 microseconds.
6. User must supply DC power and TTL or serial communication to operate.
7. Module must be attached to a suitable heat sink for proper operation.
8. Please see IPS Digital U-Type [user guide](#) and [quick start guide](#) for additional information.

Innovative Photonic Solutions, Inc.
313 Enterprise Drive
Plainsboro, NJ 08536

Phone: (732) 230-1601

sales@ipslasers.com
www.ipslasers.com



All data and statements contained herein are subject to change in accordance with Innovative Photonic Solution's policy of continual product improvement. No information contained herein is intended for use in connection with any contract except as may be first confirmed in writing by Innovative Photonic Solutions. The publication of information in this document does not imply freedom from patent or other rights of Innovative Photonic Solutions or others. OEM Laser Product